

L. C. KISER.
PISTON CYLINDER.

APPLICATION FILED APR. 16, 1903.

NO MODEL.

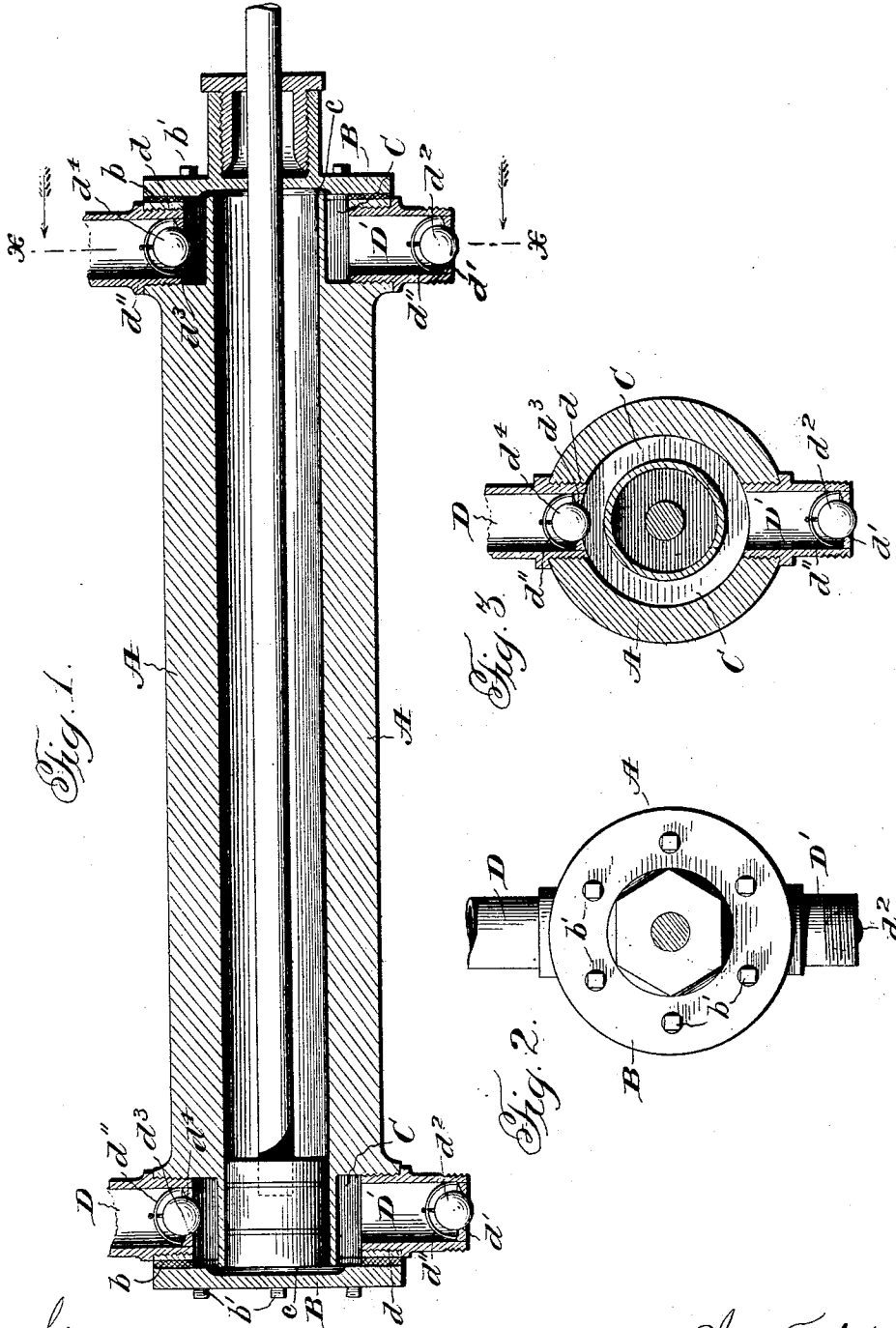

Witnesses:
Jas. E. Hutchinson.
Calvin V. Smilans.

Inventor:
Louis C. Kiser.
 By *Macmillan* atty's

UNITED STATES PATENT OFFICE.

LEWIS C. KISER, OF DECATUR, ILLINOIS.

PISTON-CYLINDER.

SPECIFICATION forming part of Letters Patent No. 745,729, dated December 1, 1903.

Application filed April 16, 1903. Serial No. 152,911. (No model.)

To all whom it may concern:

Be it known that I, LEWIS C. KISER, a citizen of the United States, residing at Decatur, in the county of Macon and State of Illinois, have invented certain new and useful Improvements in Piston-Cylinders, of which the following is a specification, reference being had therein to the accompanying drawings.

This invention relates to piston-cylinders, and has for its object the provision of a cylinder of improved construction, as will be apparent from the detailed description hereinafter and the appended claims.

An embodiment of the invention is illustrated in the accompanying drawings, forming part hereof, wherein—

Figure 1 is a longitudinal sectional view through the cylinder, the piston being shown in elevation. Fig. 2 is an end elevation, and Fig. 3 is a cross-sectional view on the line $x-x$ of Fig. 1.

Referring more particularly to the drawings, wherein like reference characters designate corresponding parts in the several views, A designates a cylinder which has a continuous smooth bore or interior surface extending from end to end thereof, and B B are heads for the open ends of said cylinder, being bolted thereto in the usual manner, with an interposed packing b , by bolts b' .

In each end of the cylinder an annular chamber C is formed, opening at the ends of said cylinder and having communication with the interior of the cylinder through the medium of the hollow or sunken portions c of the heads B B, said sunken portions forming a restricted annular passage between the heads and the ends of the cylinder, connecting the annular chambers C with the interior of the cylinder.

Each chamber C opens to a pair of radially-disposed openings d in the cylinder, said openings in turn passing through the outer wall of the cylinder and receiving the ends of pipes D and D', one an inlet or supply pipe and the other an exhaust or discharge pipe. The supply-pipes just referred to are provided with valve-seats d' and ball-valves d'' , arranged to be unseated in an inward direction, while the discharge-pipes have similar but oppositely-disposed seats d^3 and valves

d^4 , arranged to unseat in an outward direction for obvious reasons. The valve-seats are preferably removably connected to their respective pipes and carry wire cages d'' to confine the valves and prevent excessive play thereof.

It is to be understood that slight changes in the construction and arrangement of the several parts of the cylinder herein disclosed may be made without departing from the spirit of the invention.

Having thus described the invention, what is claimed as new, and desired to be secured by Letters Patent, is—

1. A cylinder of the character described having an annular chamber in the end thereof opening at said end, the head of said cylinder being formed with a sunken portion affording communication between the annular chamber and the interior of the cylinder, said cylinder also having a radial opening leading from the exterior to the annular chamber.

2. A cylinder of the character described having an annular chamber in the end thereof opening at said end, the head of said cylinder being formed with a sunken portion affording communication between the annular chamber and the interior of the cylinder, said cylinder also having an opening leading from the exterior to the annular chamber.

3. A cylinder of the character described having a chamber in the end thereof opening at said end, the head of said cylinder being formed with a sunken portion affording communication between the chamber and the interior of the cylinder, said cylinder also having a radial opening leading from the exterior to the chamber.

4. A cylinder of the character described having a chamber in the end thereof opening at said end, the head of said cylinder being formed with a sunken portion affording communication between the chamber and the interior of the cylinder, said cylinder also having an opening leading from the exterior to the chamber.

5. A cylinder of the character described having an annular chamber in the end thereof opening at said end, the head of said cylinder being formed with a sunken portion affording communication between the annular

chamber and the interior of the cylinder, and valved inlet and exhaust pipes leading from the exterior to the annular chamber.

5 6. A cylinder of the character described having a chamber in the end thereof opening at said end, the head of said cylinder being formed with a sunken portion affording communication between the chamber and the interior of the cylinder, and valved inlet and
10 exhaust pipes leading from the exterior to the chamber.

7. A cylinder of the character described having a chamber in each end thereof open-

ing at said ends, the heads of said cylinder being formed with sunken portions affording 15 communications between the chambers and the interior of the cylinder, and inlet and exhaust pipes leading from the exterior to each of said chambers.

In testimony whereof I affix my signature 20 in presence of two witnesses.

LEWIS C. KISER.

Witnesses:

B. M. DENNIS,
F. R. GOODE.